

TC1631R/S

(With TB output)
RACK MOUNT/STAND ALONE
T1/E1 FIBER OPTIC MODEM
User's Manual

MODEL: _____

S/N: _____

DATE: _____

Notice!

Although every effort has been made to insure that this manual is current and accurate as of date of publication, no guarantee is given or implied that this document is error free or accurate with regard to any specification. TC Communications, Inc. reserves the right to change or modify the contents of this manual at any time without prior notification.

© COPYRIGHT 1992-2004. ALL RIGHTS RESERVED.



Factory Default Configuration

This unit has been setup at the factory as follows:

LINE CODE				LINE LENGTH				
AMI	B8ZS	HDB3	T1/E1	0 -133	134-266	267-399	400-533	534-655

Important Note: The factory default setting for the Line Length is "0-133 feet." If the need arises to change the Line Length, contact the Technical Support Department at TC Communications, Inc before opening the unit to avoid the Warranty being voided.

SW1: Line Code switch setting (Only one setting should be marked):

AMI: SW1-3 in the
Down "On" position

B8ZS/HDB3: SW1-3 in
the Up "Off" position

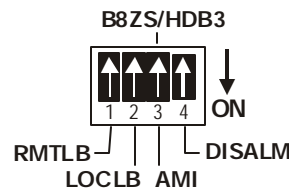
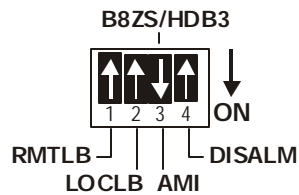

Table Of Contents

Factory Default Configuration	2
Chapter 1 - Overview	4
Description	4
Front Panel.....	5
LEDs Functions	5
SW1 External DIP Switch Functions	6
SW2 Internal DIP Switch Functions	6
Fiber Optic Specifications	6
Transmission Distances (typical)	6
Launch Power & Sensitivity	6
Rear Panel.....	7
Functional Description	8
Chapter 2 - Installation	9
Unpacking the Unit	9
Equipment Location	9
Power Supply	9
T1/E1 Connection	9
Dry Contact Alarm Relay	9
Installation Procedure	9
TC1631R/S's Configuration	10
System Start Up	11
Chapter 3 - Troubleshooting	12
General	12
All LEDs are Off	12
Alarm LED	12
Optic Cable Types	12
Calculating the Loss on the Fiber	12
Cable Connection Verification	13
Dry Contact Alarm Relay	13
Chapter 4 - Bench Tests	14
General	14
Test Equipment Requirements	14
Pre-Installation Tests	14
Local Loopback Test	14
Optical Loopback Test	15
Remote Optic Loopback Test	15
Chapter 5 - Component Placement	16
Chapter 6 - Specifications	17
Appendix A	18
Setting the E1 Interface Impedance	18
Appendix B	19
Electrical Signal Cable Connection	19
Appendix C	20
19" Rack with Dual Power Cards	20
Appendix D	22
Return Policy	22
Warranty	22

Chapter 1 - Overview

Description

The Model TC1631R/S is a T1/E1 Fiber Optic Modem that converts analog T1 or E1 signals to digital fiber optic signal and vice versa. TC1631R is for 19" rackmount and TC1631S is for standalone unit. Both have the same functions and features, the only difference is power connectors. For convenience, TC1631R/S and TC1631 will be used interchangeably throughout this manual.

TC1631 offers advanced features such as digital transmission, jitter removal and a field replaceable Line Interface Module. Because it is based on modern FPGA (Field Programmable Gate Array) technology, the IC chip counts are reduced to a minimum, hence offering extremely low power consumption (less than 3 watts) and higher reliability.

Transparent to the framing format, the TC1631R/S's T1/E1 interface shapes the transmit pulse to support CCITT G.703, or, for connecting to DSX-1 cross connects, copper line distances are from 0 to 655 feet. The internal elastic buffer removes jitter from transmit data.

The TC1631R/S has multiple LED indicators to ease installation and troubleshooting. These LEDs indicate power, operating voltage, alarm status, local and remote T1/E1 signal loss, bipolar violations, all ones warning, Optic signal sync active and more. Four DIP switches, accessible from the front panel, control settings for Line Code, Local Loopback, Remote Loopback, and Disable Alarm. The internal SW2 DIP switches, control the settings for the Line Length. The dry contact alarm relay switch provides remote alarm monitoring capability.

The TC1631R/S is compatible with all types and sizes of fiber optic cable. Fiber optic connectors are ST (optional FC). The T1 or E1 signal connects to two pairs of feed-thru detachable terminal block connectors at the rear panel. Standard input power is 12V DC. Alternate power sources are available as an option (see Chapter 6 - Specifications).

Note: The terms "TC1631R/S" and "TC1631" are used interchangeably in this manual.

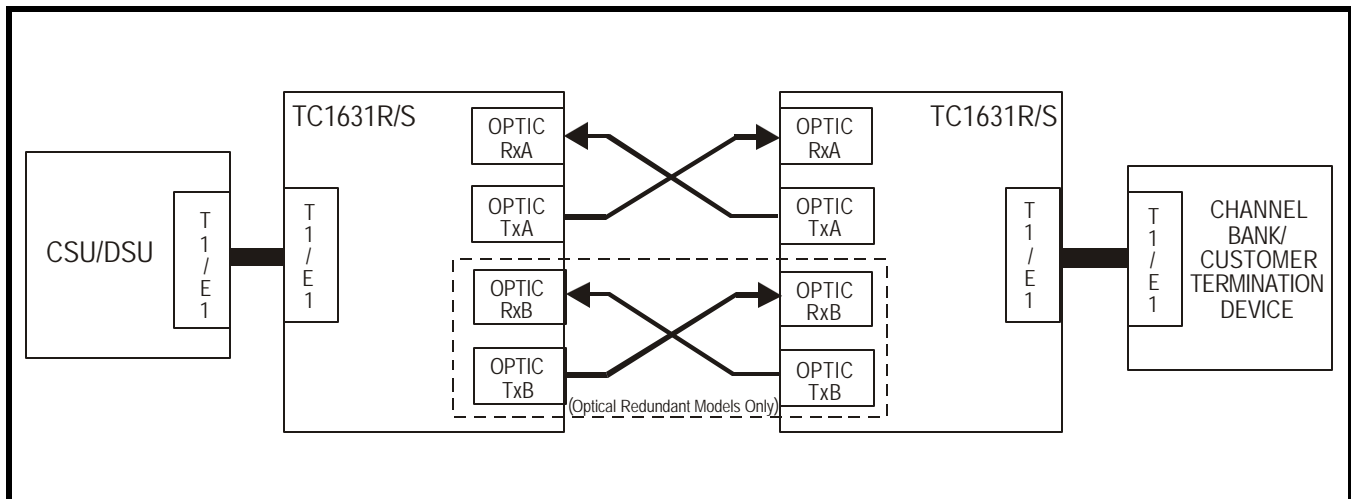

Figure 1. Typical Point-to-Point T1/E1 Application

Front Panel

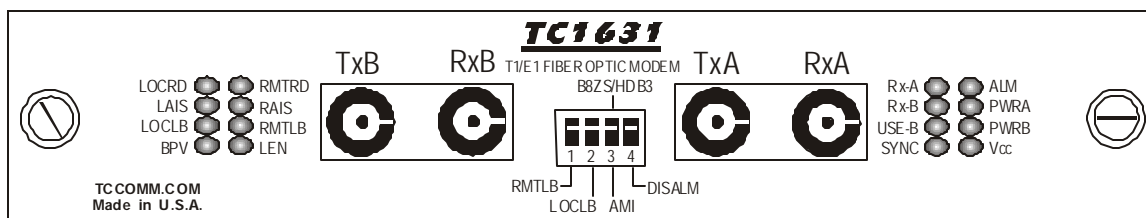

Figure 2. TC1631R/S's Front Panel

LEDs Functions

Alarm-

- ALM:** Alarm indicator. The Alarm LED will flash when following conditions occur:
- The unit is in a diagnostic mode.
 - When an invalid line code or line length is set.
 - Optic signal is lost.
 - Local T1/E1 signal is lost or all ones signal is received from customer's device.
 - Remote T1/E1 signal is lost.
 - When the "Line Distance" setting is set as "0 0 1" or "0 1 0" (with internal SW2-6, 7, and 8).

Power Supply Status-

- Power A/B:** These LEDs indicate which power source on the rear panel the unit is drawing from. If power redundancy is utilized, both LEDs will be lit.
- Vcc:** +5V Voltage indicator. This LED should light whenever power is connected to the unit. It indicates the correct operating voltage is being derived from the power source.

Optic Signal Status-

- Rx-A:** Solidly lit, it indicates optic received "OK" from primary side ("A" side).
Flashes when the optical signal at Rx-A is lost.
- Rx-B:** Solidly lit, it indicates optic received "OK" from secondary side ("B" side).
Flashes when the optical signal at Rx-B is lost or "B" side is not enabled.
- USE-B:** Solidly lit, it indicates secondary optic signal is being used due to primary optic signal lost.
"Off" when secondary optic receiver is not enabled or primary optic signal is being used.
- Note: Only when Optional Optical Redundancy is ordered on the units. Secondary side ("B" side) is optional.*
- SYNC:** Solidly lit, it indicates a valid composite signal is being received.
Flashes when the optical signal is lost.

Configuration Setting-

- LEN:** Copper Line Length indicator. "Off" whenever the minimum T1 Line Length is set to "0-133 feet" (factory default setting) or zero "0" for the E1 interface.
Solidly lit, when the T1 Line Length is set to any of the following lengths "134-266," "267-399," "400-533," or "534-655" feet, using the internal (SW2-6, 7 and 8) dip switches. (see Configuration Table - page 10). *See Important Note on page 2 before doing any changes.*

Local T1/E1 status and warning-

- LOCRD:** Local Receive Data. Solidly lit, it indicates the T1/E1 signal is received from local user's equipment.
Flashes when the T1/E1 signal is lost from local user's equipment.
- LAIS:** Local All Ones. When flashing, it indicates "all ones" signal received from user's equipment.
- BPV:** Bipolar Violations. This LED will flash when bipolar violations (Line Code violations) are detected or the Line Length setting is invalid.
- LOCLB:** Local Loopback. When lit, it indicates that the LOCLB function is enabled (SW1-2 is On).

Remote T1/E1 status and warning-

- RMTRD:** Remote Receive Data. Solidly lit, it indicates the T1/E1 signal is received from remote user's equipment.
Flashes when the T1/E1 signal is lost from remote user's equipment.
- RAIS:** Remote All Ones. When flashing, it indicates "all ones" signal received at the remote TC1631 unit.
- RMTLB:** Remote Loopback. When lit, it indicates that the RMTLB function is enabled (local SW1-1 is On).

SW1 External DIP Switch Functions

Slide switch to the Down (On) position to activate the function.

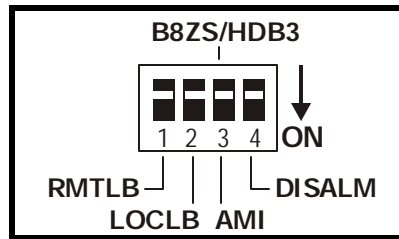

SW1-1, Remote Loopback Test: This switch activates the remote unit into Remote Loopback function. The composite optic signal is transmitted to the remote unit and decoded, then looped back to the local unit.

SW1-2, Local Loopback Test: This switch activates the Local Loopback function. The T1/E1 signal is received and decoded, then looped back to the T1/E1 "out" terminals for diagnostic testing.

SW1-3: This switch selects the Line Code for **AMI**, **B8ZS** or **HDB3**.

"Up" for **B8ZS** or **HDB3** and "Down" for **AMI**.

SW1-4, Disable Alarm: This switch disables the alarm buzzer and dry contact relay alarm.

SW2 Internal DIP Switch Functions (See Important Note on page 2 before doing any changes)

Slide switches to the Right (On) position to activate the function.

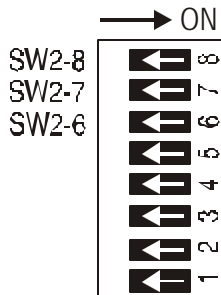

SW2-6/SW2-7/SW2-8: These switches define the DSX-1 cross connect distance. There are 5 partitions to choose from. In a T1 application, this is the length of twisted pair cable connecting the TC1631R/S to the user's equipment, which may be a CSU or DSU. The cable lengths can be from 0 to 655 feet (see Figure 5).

Fiber Optic Specifications

Transmission Distances (typical)

The TC1631R/S is compatible with all popular sizes and types of fiber. Transmission distances up to 3km* are typical over Multimode fiber at 850nm and 4km* at 1310nm. Distances to 34km* are typical over Single Mode fiber at 1310nm.

Launch Power & Sensitivity

Transmitter:	LED/ELED; typical Launch Power -	-18dBm* (850nm/1310nm MM, @62.5/125µm) -18dBm* (1310nm Single Mode, @9/125µm)
Receiver:	PIN Diode; typical Sensitivity -	-35dBm* (850nm/1310nm MM, @62.5/125µm) -35dBm* (1310nm Single Mode, @9/125µm)

*Launch power, sensitivity and distances are listed for reference only. These numbers may vary. Contact factory for higher loss budget requirements.

Rear Panel

TC1631S Rear Panel

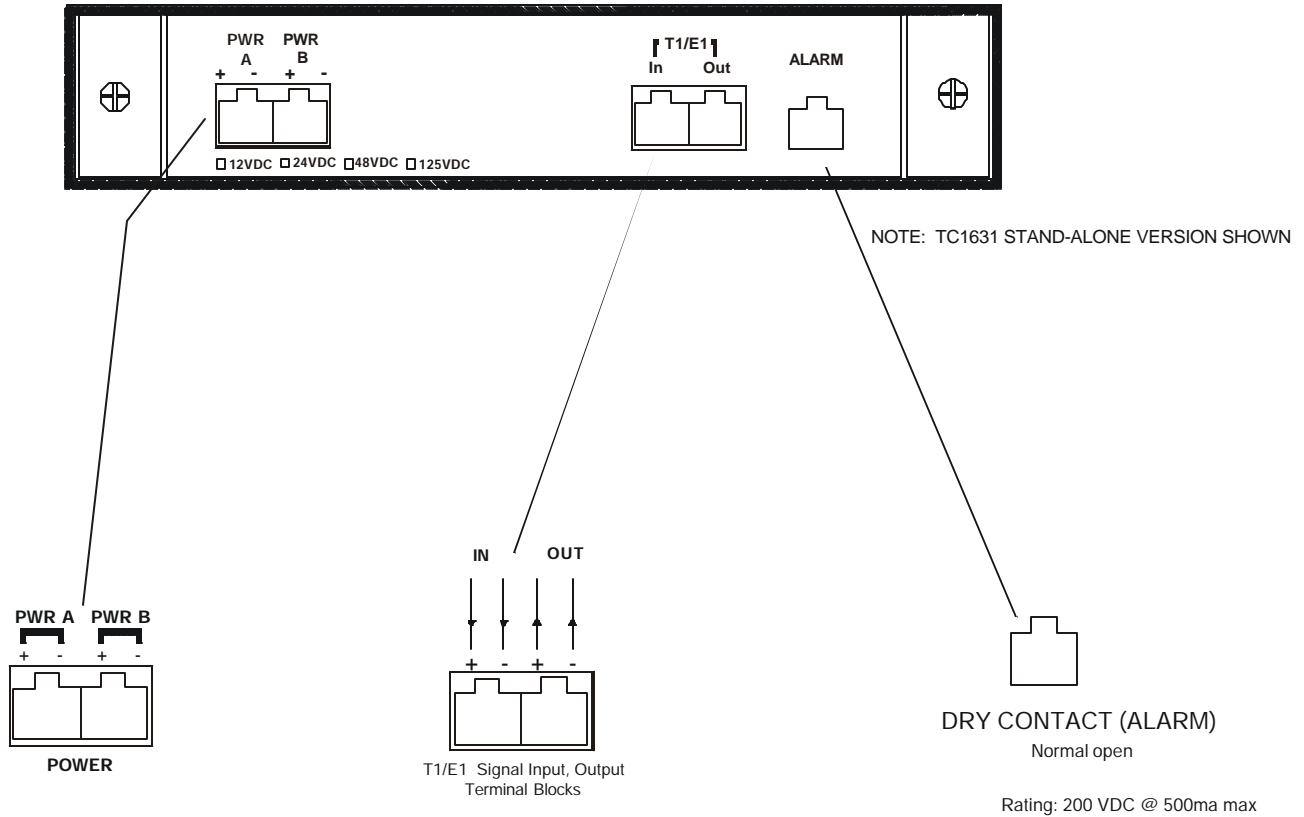

Note: The T1/E1 signal is bipolar, independent of the polarity. Polarity on the "IN" & "OUT" terminal block connector shown above is shown for reference only.

12 VDC @ 350mA (typical)
24 VDC @ 175mA (typical)
48 VDC @ 100mA (typical)
125VDC @ 35mA (typical)

Figure 3. TC1631S Rear Panel

Functional Description

As shown in figure 4, the TC1631 consists of five basic function blocks: DIP switches, LEDs, T1/E1 interface, T1/E1 signal processor and optic interface.

DIP switches are used to configure the TC1631 according to a customer's application such as line code and line distances. LEDs are used to display corresponding DIP switches settings, power supply status, optic signal status, signal warnings, alarm, etc... the T1/E1 interface converts T1/E1 analog signals to digital signals and provides local and remote loopback function. The signal processor composes T1/E1's timing and data to a bit stream. The optic interface converts the electrical bit stream to an optic signal and vice versa.

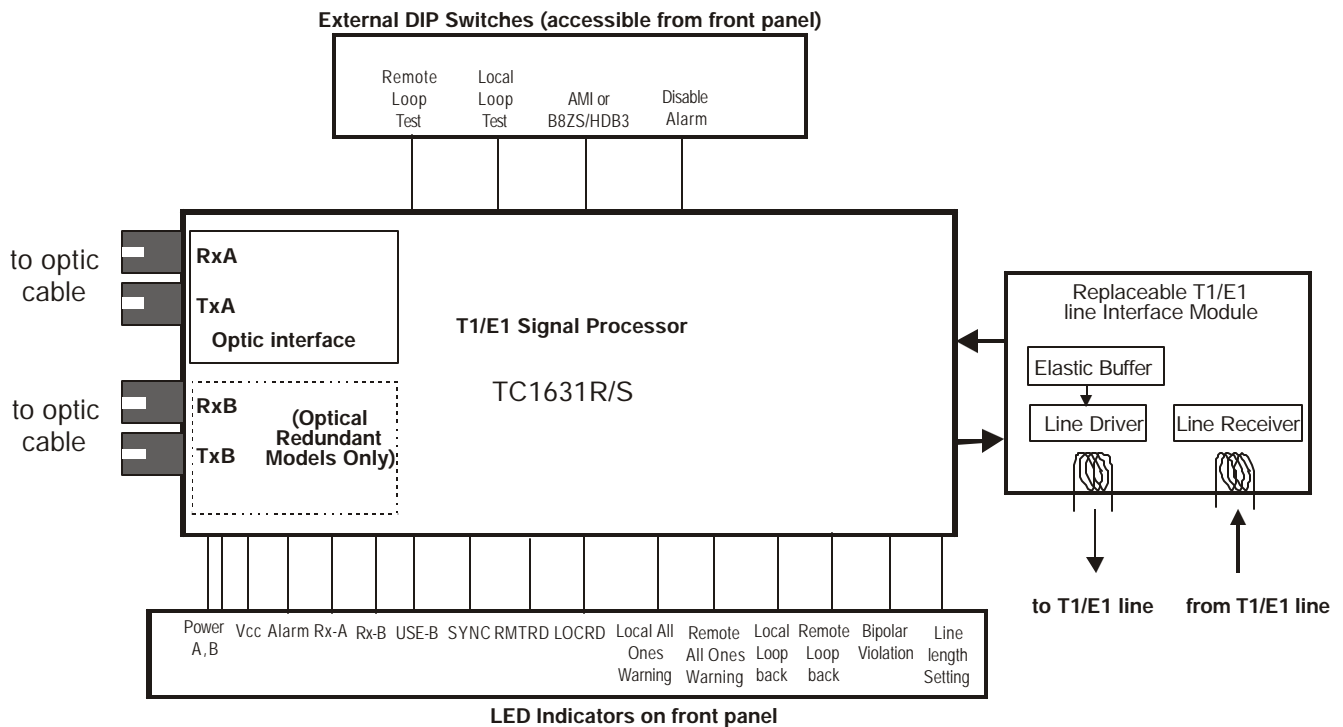

Figure 4. TC1631R/S Functional Diagram

Chapter 2 - Installation

Unpacking the Unit

Before unpacking any equipment, inspect all shipping containers for evidence of external damage caused during transportation. The equipment should also be inspected for damage after it is removed from the container(s). Claims concerning shipping damage should be made directly to the pertinent shipping agencies. Any discrepancies should be reported immediately to the Customer Service Department at TC Communications, Inc.

Equipment Location

The TC1631R/S should be located in an area that provides adequate light, work space, and ventilation. Avoid locating it next to any equipment that may produce electrical interference or strong magnetic fields, such as elevator shafts or heavy duty power supplies. As with any electronic equipment, keep the unit from excessive moisture, heat, vibration, and freezing temperatures.

Power Supply

Standard input power to the TC1631S is 12VDC @350mA. There are two power jacks at the rear panel for power redundancy. TC1631R is the rackmount version of the TC1631S. It can be inserted into the card slot when power is on (hot swappable).

T1/E1 Connection

Two pairs of terminal block connectors are provide for the connection of the T1/E1 wire pairs. When viewing the rear panel, the left pair of terminal block connectors are for T1/E1 signal going into the TC1631R/S (receive), while the right pair of terminal block connectors are for the transmit signal coming out of the unit, refer to page 7.

Dry Contact Alarm Relay

A terminal block connector at the rear panel provides for the Dry Contact Alarm Relay. Normally in the OPEN position, any alarm condition will force the switch to the CLOSED position. This relay can be configured by the user if necessary (see Chapter 3 - Troubleshooting).

Installation Procedure

The TC1631R/S is designed for quick and easy installation. First, configure the modem for your specific application by setting the Line Code DIP switch. Once configured, you can connect the optical, T1/E1 signal source and power.

Installation Procedure:

1. Select the Line Code (SW1-3).
2. For T1, the Line Length has been factory set to "0-133 feet."
3. Connect the T1/E1 signal source to the terminal block connectors on the rear panel.
4. Connect the optic cables. Verify single mode or multimode optic cable according to your TC1631 ordered. Using incorrect optic cables will result in a malfunction. Verify optic connections.
5. Connect the power. All the LEDs (except for PWRA and/or PWR B and Vcc) should flash for approximately one second.

After installation is completed, it is an excellent idea to verify the optical cable loss. This reading will both verify the integrity of the circuit and provide a benchmark for future troubleshooting efforts.

TC1631R/S's Configuration

1. Select the application's Line Code: SW1-3. Set the switch to the Up (Off) or Down (On) position.

AMI: Set SW1-1 to the Down (On) position.

B8ZS or HDB3: Set SW1-3 to the Up (Off) position.

2. The copper Line Length setting for T1 has been set as per factory default to "0-133 feet":

See Important Note on page 2 before doing any changes.

Slide the appropriate switches to the Right (On) position. Internal SW2-6, 7, 8 (see Figure 5).

Depending on the copper distance between the TC1631R/S and the T1 cross connect, set the copper Line Length for the T1 transmit line driver according to the table below. When connecting to DSX-1 cross-connects for copper Line Lengths ranging from 0 to 655 feet, see DIP Switch Functions on page 6. There is no need to set the copper Line Length for E1 applications; set SW2-6, 7, and 8 to the Left (Off) position.

Note: The "Line Length" settings for "0 0 1" and "0 1 0" are invalid. If the copper "Line Length" is set to (0 0 1) or (0 1 0), then the Alarm and BPV LEDs will flash, indicating the setting is invalid.

Legend: 0 = Off 1 = On			LINE LENGTH SW2-6 SW2-7 SW2-8		
AMI		0-133 feet	0	1	1
		134-266 feet	1	0	0
		267-399 feet	1	0	1
		400-533 feet	1	1	0
		534-655 feet	1	1	1
B8ZS		0-133 feet	0	1	1
		134-266 feet	1	0	0
		267-399 feet	1	0	1
		400-533 feet	1	1	0
		534-655 feet	1	1	1
HDB3		0-655 feet	0	0	0

Figure 5. TC1631R/S Configuration Table

3. Connect the T1 or E1 signal.

T1 signal connection for 100 ohm line: Connect the incoming T1 signal (from your equipment) to the "in" terminal blocks on the rear panel; they are not polarity sensitive. A valid T1 signal will cause the "LOCRD" LED turn "On." Connect the outgoing T1 signal (received from the optical cable) to the "out" terminal blocks.

E1 signal connection (The E1 interface can be used for either 75 or 120 ohm line - see Appendix A):

75 ohm line: Connect the incoming signal (from your equipment) to the "in" BNC adapter. Connect the outgoing signal (received from optical cable) to the "out" BNC adapter.

120 ohm line: If twisted-pairs are used, connect the wires in the same way as the T1's wire. If dual coaxial is used, connect the cores to the "in" terminal blocks for the incoming signal and to the "out" terminal blocks for the outgoing signal (each cable has two cores & a shield).

4. Verify optical connections:

Make sure the local TC1631's optic "TxA" is connected to the remote TC1631's optic "RxA" (and vice-versa).

For dual optical models only, make sure the local TC1631's optic "TxB" is connected to the remote TC1631's optic "RxB" (and vice-versa).

5. Connect power to both units.

System Start Up

When power is initially connected, the following conditions should be observed:

1. The "POWER A" and/or "B" LED is lit.
2. The "LOCRD" LED is On, indicating a valid T1 or E1 signal input.
3. The "ALARM" LED should be Off.

Start the T1/E1 signal transmission:

4. The "POWER A" and/or "B" LED should be solidly lit.
5. The "SYNC" LED should be lit, indicating a valid optic signal is received.
6. The "LEN" copper Line Length LED will generally be "Off" since "0 to 133 feet" is the factory default setting.

Lit when any of the following copper line lengths "134-266," "267-399," "400-533," or "534-655" feet is selected. (*See Important Note on page 2.*)

Note: If the modem is not functioning properly at this point, please refer to Chapter 3 - Troubleshooting.

Chapter 3 - Troubleshooting

General

Alarm conditions occur whenever an optical problem or "fault" condition is detected by the TC1631.

All LEDs are Off

If no LEDs are lit on the unit, check the DC power supply, terminal block connector plug, change to alternate power jack on the rear panel, fuses A and/or B indicated on page 16, and/or the power source. If the problem persists, contact the Technical Support Department at TC Communications, Inc.

Alarm LED

When an alarm condition is detected, the Alarm LED will flash. The following fault conditions will cause the alarm to be triggered:

1. Optic signal lost from optic "RxA" or "RxB" (for optical redundant models only).
2. Optic signal is marginal, which causes invalid data packets to be received; the "SYNC" LED will "Flash."
3. Received "space" or "mark" from local T1/E1 device.
4. An invalid Line Code setting exists.
5. The Line Length setting does not match the Line Code.
6. The local or remote T1/E1 signal is lost; the "LOCRD" or "RMTRD" LED will be also be flashing.

Note: The "RMTRD" LED will "Flash" when there is no fiber cable connected or the fiber cable is bad.

Optic Cable Types

Conventionally, fiber optic cable with **yellow-colored** insulation is used for Single Mode applications; **gray or orange-colored** insulated cable is for Multimode use. If Multimode cable is used in a Single Mode application, the test results could be erroneous and confusing.

Calculating the Loss on the Fiber

The fiber optic link and/or connectors are frequently the source of various problems. Check out the connectors and the integrity of the link first. Ideally, the link should be calibrated for total loss after the installation has been completed. This will accomplish two things: (1) it will verify that the total loss of the link is within the loss budget of the device and (2) it will provide a benchmark for future testing. For example, a system that has been tested as having 6dB total loss when installed and suddenly tests out as having a loss of 10dB probably has a connector or link problem.

These are the reference values we use to calculate the loss on the fiber:

Multimode 850nm	:	3 dB loss per km on 62.5/125µm cable*
Multimode 1310nm	:	2 dB loss per km on 62.5/125µm cable*
Single Mode 1310nm	:	0.5 dB loss per km on 9/125µm cable*
Single Mode 1550nm	:	0.25 dB loss per km on 9/125µm cable*

**These numbers are listed for reference only. We recommend an OTDR reading be used to determine actual link loss.*

Cable Connection Verification

Electrical Cables:

1. Make sure all electrical signal connections match the pin assignments (I/O) for the device (check User's Manual if necessary).
2. Verify the signal connections by checking the status LEDs on the front panel of the TC1631R/S. If the "LOCRD" LED is "Flashing", a transmit signal is not being detected from the local device. If the "RMTRD" LED is "Flashing", no response signal is being detected from the remote device.
3. Verify that the correct Line Code setting (and copper Line Length setting for T1) has been configured and that the appropriate LEDs light to match the settings selected.
4. Conduct a Local Loopback Test to help isolate an electrical interface problem (see Chapter 4 - Bench Tests).

Optic Cables:

If the "SYNC" LED on the front panel is **flashing**, this is an indication that the optical signal is not being correctly received. Usually, unsecured fiber optic connectors or faulty cable are to blame. A good connection is indicated by the "SYNC" LED on the front panel being solidly lit. This indicates that the receiving cable is correctly connected to Remote unit's optic "TxA" or "TxB" (dual optic models only).

Dry Contact Alarm Relay

TC1631 has built-in Dry Contact Alarm Relay. The status for the alarm relay is "normal open." It is triggered by the following major alarm conditions:

Optic signal lost

Local T1/E1 signal lost

Local user's T1/E1 device is sending "mark" data pattern

Local user's T1/E1 device's signal is causing bipolar violations

Invalid line code setting

Invalid copper line length setting

The electrical rating for the dry contact alarm relay is

200VDC max

500 mA max.

switching power is 10 watts max.

General

It is highly recommended to conduct bench tests before actual installation. Bench testing allows the user to become familiar with all the functions and features of the TC1631 in a controlled environment. Knowledge of the TC1631's functions and features will ease installation and troubleshooting efforts later on.

Test Equipment Requirements

End-user equipment required for testing:

1. Model 5575A T1 Micro BERT (Bit Error Rate Tester) Test Set with Terminal Block Connectors.
2. Two optical cable jumpers (patch cords) with appropriate connectors.

Pre-Installation Tests

1. Make sure the appropriate power supply accompanies the TC1631R/S unit (see page 9).
2. To verify that the unit functions properly, connect power to the unit's "PWR A" or "B" terminal blocks (be sure to observe correct polarity) without connecting any other cables to the unit.
3. On the front panel, the appropriate green Power "A" or Power "B" LED should be illuminated (depending on whether you plug into the "A" or "B" terminal on the back of the unit). Both lights should be on if you utilize power redundancy (power is plugged into both "A" and "B" on the rear panel).
4. The "ALM," "Rx-A," "SYNC," "RMTRD," and "LOCRD" LEDs should be flashing.
5. The "Vcc" LED should be illuminated. Please note: all other LEDs can be in a random state (flashing, solidly lit, or off) as only upon proper receipt and transmission of a signal will the TC1631R/S unit set its LEDs appropriately for normal operation. Proceed to the Local Loopback Test.

Local Loopback Test

The purpose of this test is to verify 1) the signal source recognition and 2) the connection between the incoming signal and the TC1631R/S's terminal blocks.

1. Make sure your BERT tester is turned on and configured with the same setup as the TC1631R/S (and your application).
2. Plug in the terminal blocks from the BERT tester to the TC1631R/S's connectors on the rear panel. When the input and output are connected correctly, the "LOCRD" LED on the TC1631R/S will turn On.
3. Slide SW1-2 (Local Loopback) to the Down (On) position. The "LOCLB" LED should be lit on the front panel, indicating that the unit is in LOCLB mode.

Note: If this test is done without any fibers connected to the unit, the "ALM," "Rx-A," "SYNC," and "RMTRD" LEDs will flash. Otherwise, they should be solidly lit.

4. Make sure the "TERM" or "BRIDGE" LED on the tester is lit, and that the tester is in the "RUN" mode. The tester should indicate a "SYNC" signal.
5. If any other LEDs illuminate or flash, make sure that all DIP switches on the TC1631R/S are in the correct position, then reset the BERT tester. You should not see any bit errors. To verify this, inject an error using the BERT tester to see if it will be recorded by the tester, then verify that no additional errors appear after the user injected error. When done with the test, return SW1-2 to the up "Off" position and proceed to the Optical Loopback Test.

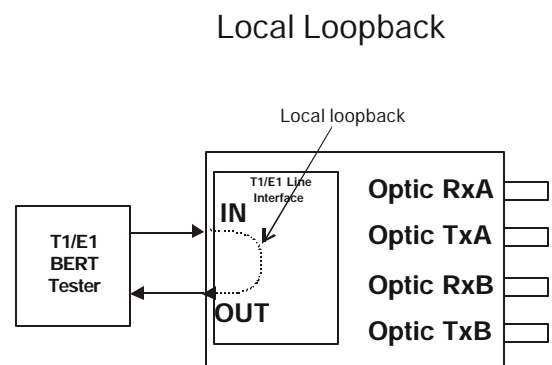

Optical Loopback Test

At any time you may use a short optic cable to loopback the unit's Optic "TxA" to "RxA" or "TxB" to "RxB" (dual optic models only). The "SYNC" LED on the front panel should light (solid) when a good optic signal is received. This test verifies the optic transmitter's function as well as the receiver's. Upon successful completion of this test, proceed to the Remote Loopback Test.

Local Optical Loopback

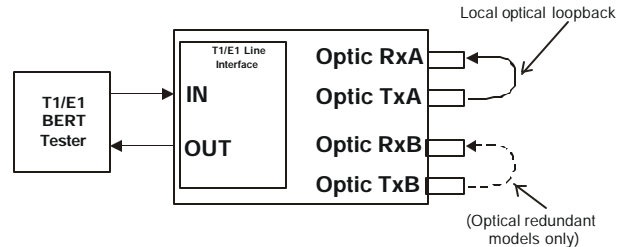

Remote Optical Loopback Test

1. Connect a second TC1631R/S unit. As with the first unit, follow the bench test steps on the previous page. When you have completed the Local Loopback & Optical Loopback tests for the second unit, proceed to the next step.
2. Remove the optical jumper cable from the local unit's "RxA" and connect it to the second unit's optic "RxA." Add a second optical jumper cable to connect the local unit's "RxA" to the second unit's "TxA."
3. Verify that both TC1631R/S units have the same Line Code and Line Length settings.
4. On the local TC1631R/S, slide SW1-1 (Remote Loopback) to the Down (On) position. The "RMTLB" LED will momentarily flash until it receives the remote optical signal, then it should be lit, indicating that the unit is in RMTLB mode. (Note, other LEDs might flash for about three seconds, but will settled down to their normal state.)
5. The "PWRA and/or PWRB," "Vcc," "Rx-A," "SYNC," "RMTRD," and "LOCRD" LEDs on the remote TC1631R/S's front panel should be lit, as well as on the local unit.
6. Make sure the "TERM" LED on the tester is lit, and that the tester is in the "RUN" mode. The tester should indicate a "SYNC" signal.
7. If any other LEDs illuminate or flash on the unit, make sure that all DIP switches on both of the TC1631's are in the correct position, then reset the BERT tester. You should not see any bit errors.
8. At this point, both units tested will have passed all electrical and optical tests and will have been verified that they are functioning properly. When done, return SW1-1 to the Up "Off" position. Proceed to the next TC1631 unit to be tested or begin verifying other equipment and cabling in your application (if you have not already done so).

Remote Optical Loopback

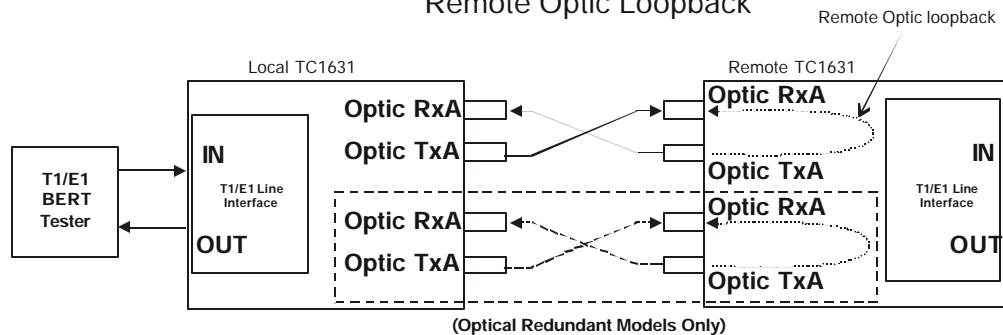

Chapter 5 - Component Placement

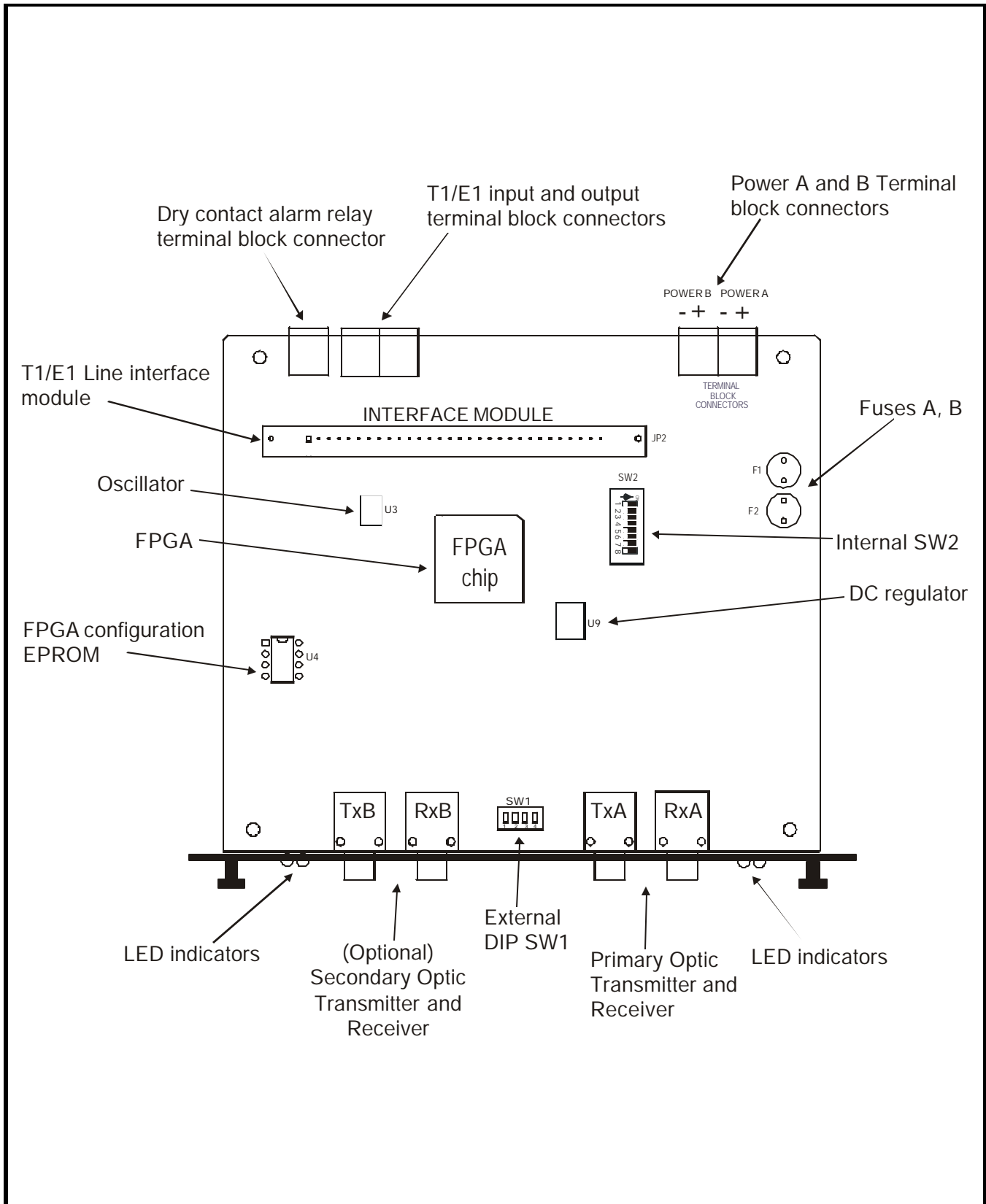

Figure 6. TC1631R/S's Internal PCB

Chapter 6 - Specifications

Data Rates

T1 (per channel) 1.544 Mbps
 E1 (per channel) 2.048 Mbps
 Line Code AMI, B8ZS, or HDB3

Optical

Transmitter LED/ELED
 Receiver PIN Diode
 Wavelength 850nm/1310nm Multimode
 1310nm Single Mode
 Fiber Optic Connectors ST* (FC optional)
 Loss Budget 15dB Multimode 850nm/1310nm @62.5/125µm
 20dB** Single Mode @9/125µm

Electrical

Interface T1/E1
 T1 Connector (100 ohm) Terminal Block
 E1 Connector (120 ohm) Terminal Block
 E1 Connector (75 ohm) Terminal Block with BNC Adapter

System

Bit Error Rate 1 in 10¹⁰ or better
 Visual Indicators ALARM, PWR A, PWR B, Vcc, SYNC, Rx-A, Rx-B, USE-B,
 RMTLB, LOCLB, BPV, LEN, AMI, LAIS, RAIS, LOCRD, RMTRD
 Dry Contact Alarm 200VDC, 500mA (10watts)

Power Source

Standard 12V DC(9-14VDC) @350mA (typical)
 Optional 115V or 230V AC with external power cube
 Optional 24VDC (18-36VDC), 48VDC (36-75VDC), or 125VDC

Temperature

Operating -10°C to 50°C
 Hi-Temp -20°C to 70°C
 Storage -40°C to 90°C
 Humidity 95% non-condensing

Physical

Rack Mountable Card

Height (17.7 cm) 7.0"
 Width (3.2 cm) 1.25"
 Depth (14.8 cm) 5.75"
 Weight (192 gm) 5.44 oz

Stand Alone Unit

Height (18.2 cm) 7.2"
 Width (3.5 cm) 1.4"
 Depth (16.6 cm) 6.60"
 Weight (512 gm) 14.5 oz

*ST is a trademark of AT&T

**Contact factory for requirements higher than 20dB .

Appendix A

The E1 interface impedance on the TC1631R/S is user configurable by changing the jumpers on the interface module. Please follow the instructions below to set the E1 impedance appropriately.

Setting the E1 Interface Impedance

1. Unscrew the 2 front panel screws and slide the unit out of it's housing.
2. Locate the interface module at board location JP2 (the board plugs vertically into the main board's socket).
3. For 75 ohm impedance, the jumpers on the interface module should be set as follows:

JP2 and JP3----- installed

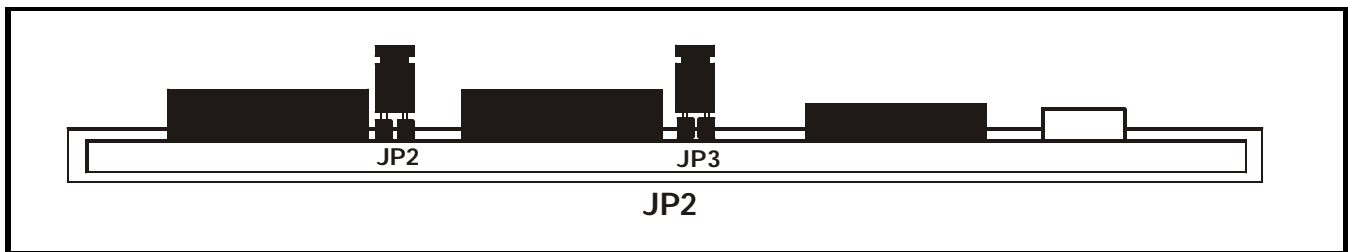

Figure 7. TC1631R/S's E1 (75 ohm) Interface Module Configuration

4. For 120 ohm impedance, the jumpers on the interface module should be set as follows:

JP2 and JP3----- removed

5. Slide the unit back into the housing and secure the 2 front panel screws.

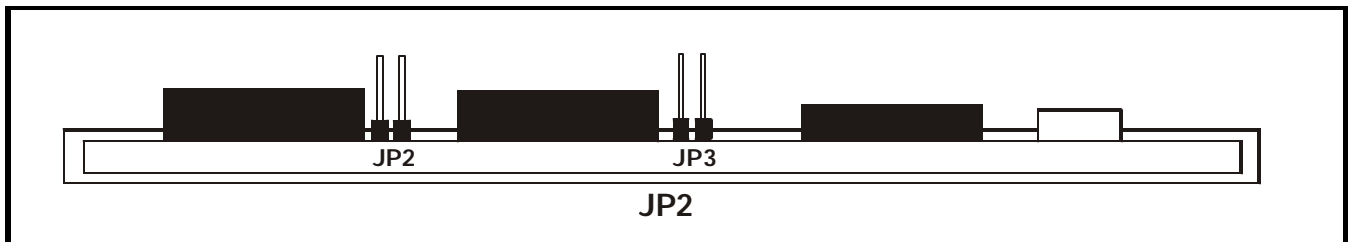

Figure 8. TC1631R/S's E1 (120 ohm) Interface Module Configuration

Appendix B

Electrical Signal Cable Connection

The user's device may have a DB15 or RJ45 connector. The following connection diagrams illustrate the signal flow direction and pin assignments typically used with these connectors.

Note: The polarity of the T1/E1 signal is bipolar, independent of the polarity. Polarity is shown for reference only.

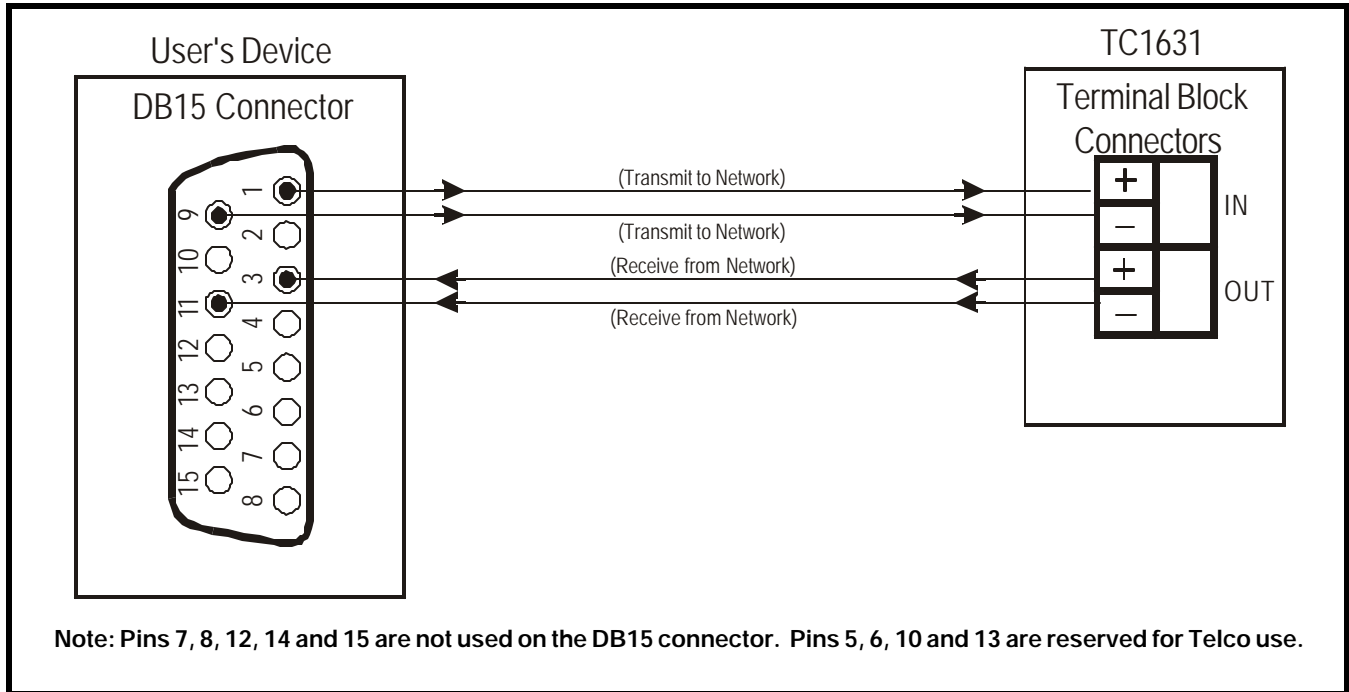

Figure 9. DB15 Connection Diagram

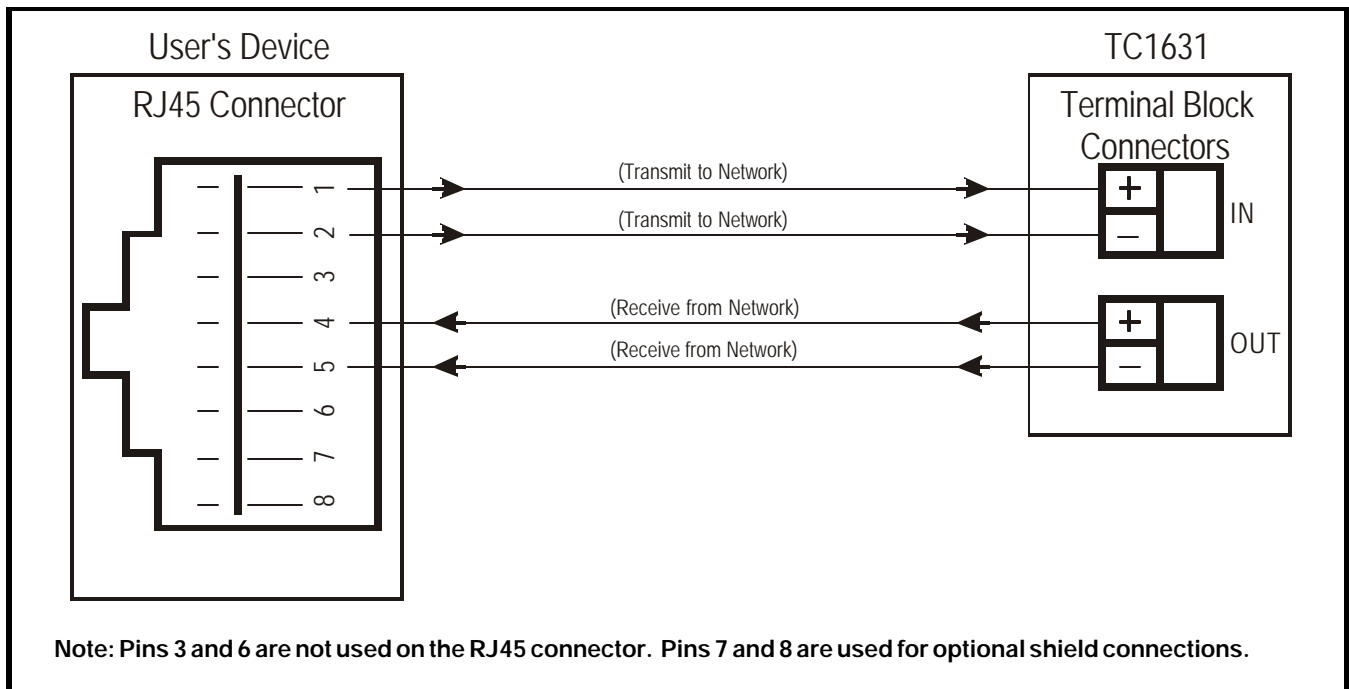

Figure 10. RJ45 Connection Diagram

Appendix C

19" Rack with Dual Power Cards

The picture shows the 19" rack with dual power supply cards. It consists of two subassemblies; TCRM192-D-48 which is the 19" rack with dual 48VDC to 12VDC power cards and the TCRM192-BKPL, which is the power back plane. The power card can be ordered for universal AC input or 24VDC input. The output of each kind of power card is 12VDC, different input voltage has different output power rating. They are listed as following:

TCRM192-D-48: 19" rack with dual power cards, each has 48VDC(36-75VDC) input, 12VDC output and 150 Watts.

TCRM192-D-24: Same as above but with 24VDC(18-36VDC) input, 12VDC output and 100 Watts output power.

TCRM192-D-01: 19" rack with dual power cards, each has universal AC input (90VAC to 240VAC, 50Hz to 60Hz) with 12VDC output. Maximum output power is 65 Watts. The diagram on the next page shows the equivalent circuits.

The add-on subassembly to the 19" rack is TCRM-bkpl, which is a power strip PCB connected to both power cards via two pair cable assembly. This power back plane has built-in fuses and power indicators to ease installation and troubleshooting.

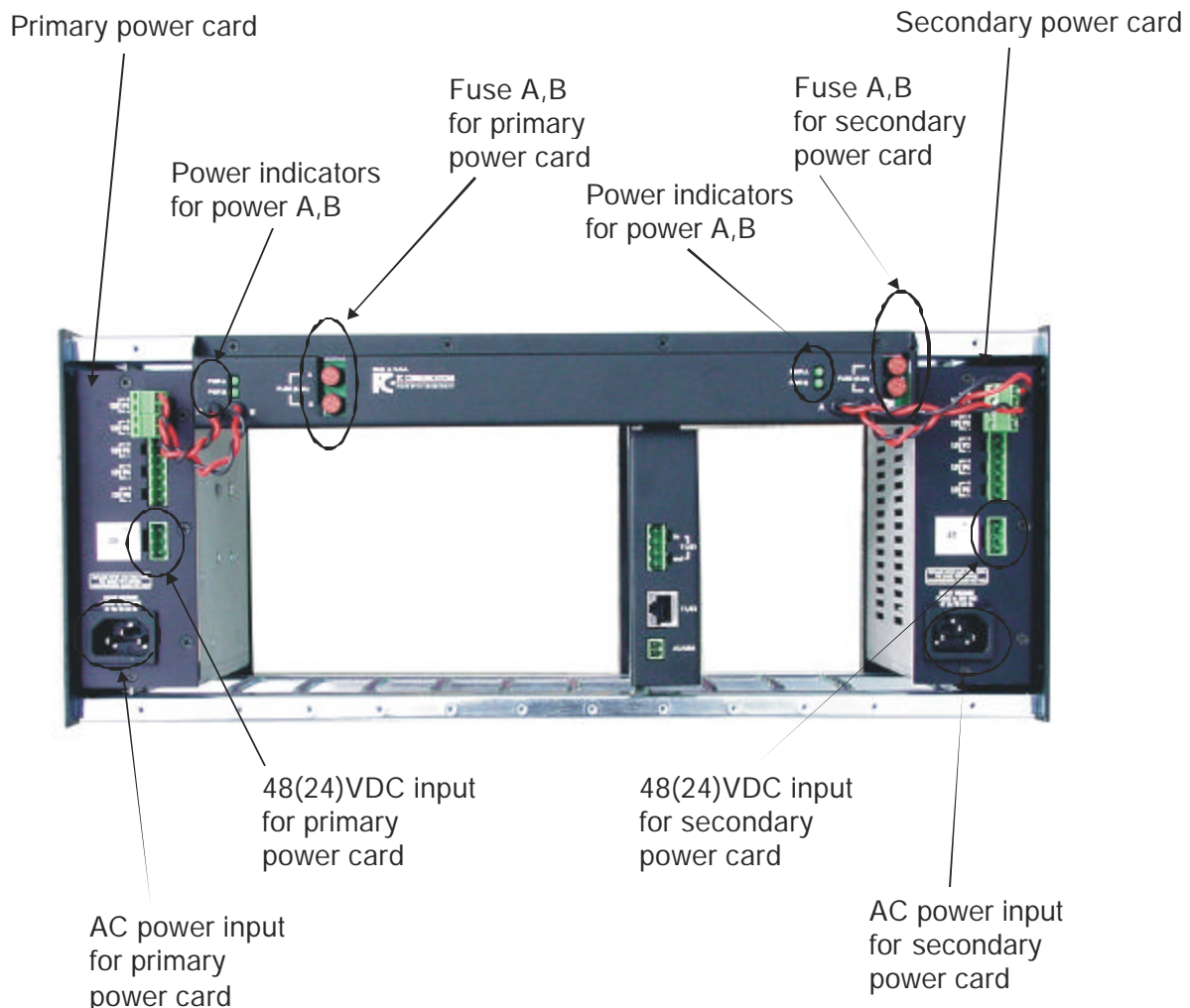

TC1630 RACKMOUNT POWER SUPPLY

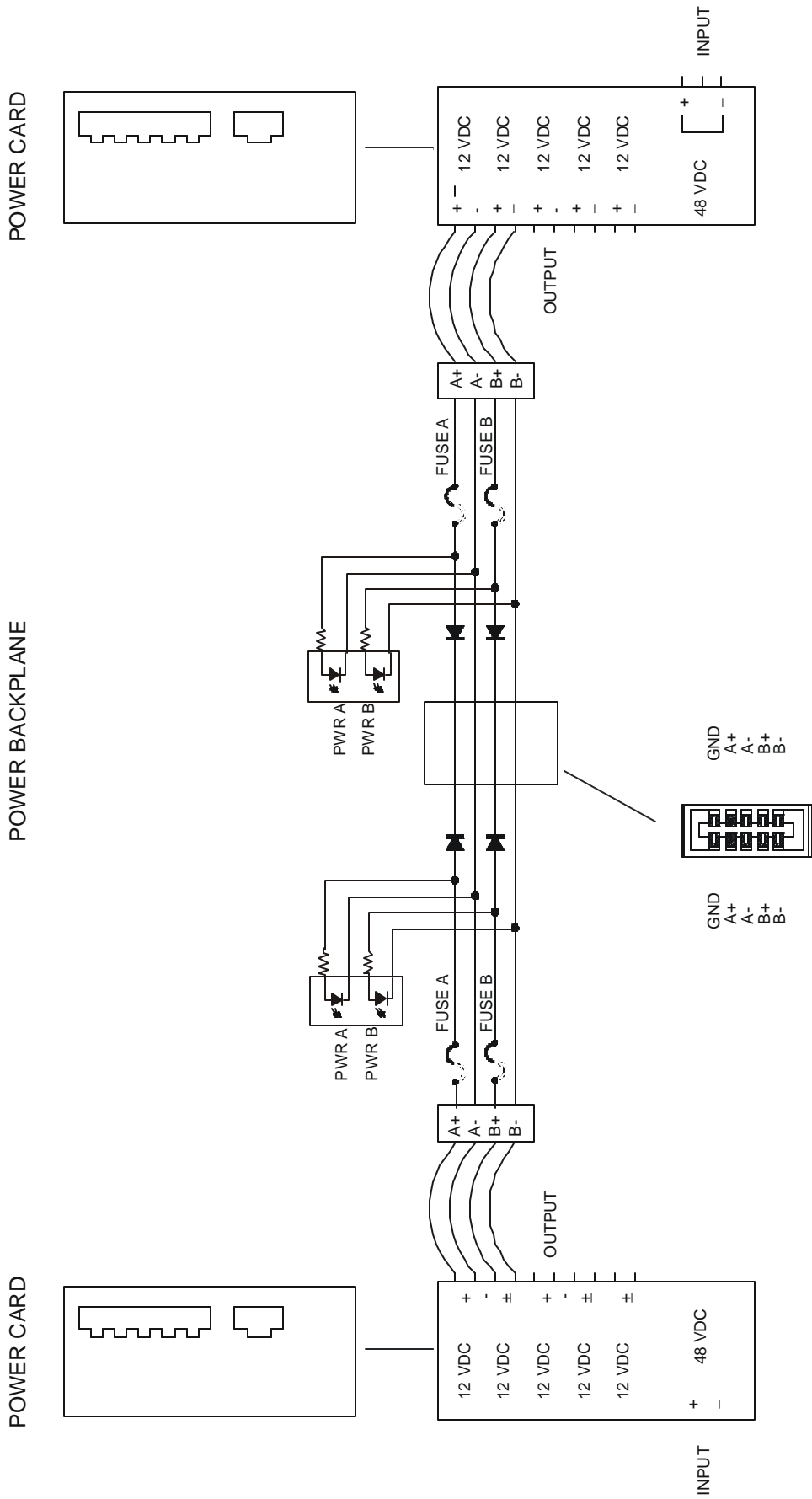

INPUT @36-75V
 OUTPUT @12V + 1% , (5 OUTPUTS)
 MAX OUTPUT POWER: 150W

EDGE CONNECTOR TO
 TC1630R CARD (10 X)

Appendix D

Return Policy

To return a product, you must first obtain a Return Material Authorization number from the Customer Service Department. If the product's warranty has expired, you will need to provide a purchase order to authorize the repair. When returning a product for a suspected failure, please provide a description of the problem and any results of diagnostic tests that have been conducted.

Warranty

All products manufactured by TC Communications, Inc. come with a five year (beginning 1-1-02) warranty. TC Communications, Inc. warrants to the Buyer that all goods sold will perform in accordance with the applicable data sheets, drawings or written specifications. It also warrants that, at the time of sale, the goods will be free from defects in material or workmanship. This warranty shall apply for a period of five years from the date of shipment, unless goods have been subject to misuse, neglect, accident, damage, improper installation or maintenance, or alteration or repair by anyone other than Seller or its authorized representative.

Buyer should notify TC Communications, Inc. promptly in writing of any claim based upon warranty, and TC Communications, Inc., at its option, may first inspect such goods at the premises of the Buyer, or may give written authorization to Buyer to return the goods to TC Communications, Inc., transportation charges prepaid, for examination by TC Communications, Inc. Buyer shall bear the risk of loss until all goods authorized to be returned are delivered to TC Communications, Inc. TC Communications, Inc. shall not be liable for any inspection, packing or labor costs in connection with the return of goods.

In the event that TC Communications, Inc. breaches its obligation of warranty, the sole and exclusive remedy of the Buyer is limited to replacement, repair or credit of the purchase price, at TC Communications, Inc.'s option.

To return a product, you must first obtain a Return Material Authorization (RMA) number and RMA form from the Customer Service Department. If the product's warranty has expired, you will need to provide a purchase order to authorize the repair. When returning a product for a suspected failure, please fill out RMA form provided with a description of the problem(s) and any results of diagnostic tests that have been conducted. The shipping expense to TC Communications should be prepaid. The product should be properly packaged and insured. After the product is repaired, TC Communications will ship the product back to the shipper at TC's cost to U.S. domestic destinations. (Foreign customers are responsible for all shipping costs, duties and taxes [both ways]. We will reject any packages with airway bill indicating TC communications is responsible for Duties and Taxes. To avoid Customs Duties and Taxes, please include proper documents indicating the product(s) are returned for repair/retest).