

Standalone/Wallmount Chassis

1S (TCSD11-1)
2S (TCSD11-2)

- Ruggedized design for Harsh Environments
- Designed to Hold JumboSwitch Family of Cards
- Extreme Temperature (-40°C to +80°C) Optional
- Power Supply Managed via Web, SNMP, Serial Console or Telnet (2S Only)
- Various AC & DC Power Ranges
- Built-In Power Redundancy
- Member of the JumboSwitch® Product Family



JumboSwitch 1S & 2S Standalone Chassis

The JumboSwitch 1S & 2S standalone/wallmount chassis are designed to hold JumboSwitch family cards. The 1S chassis holds one interface card. The 2S chassis holds one Main/Management card and one interface card.

Both chassis come standard with dual load-sharing 12VDC power supplies. Here are the options:

- 12VDC (standard)
- 24VDC and -48VDC (optional)
- 115VAC, 230VAC and 240VAC (via External AC Power Adapter)

The dual load-sharing power supplies feature automatically switch over in the event of a power failure. Through the TC3840 Main/Management card, the power supply on the 2S can be remotely managed via Web, SNMP, Serial Console or Telnet. Power supply cycling and monitoring ON/OFF status can be done remotely.

Standard temperature range is -20°C to +70°C and the extreme temperature option is -40°C to +80°C.

(Please see page 3 for dimensions.)

Applications

Sturdy and durable, the 1S/2S standalone/wallmount chassis house various combinations of JumboSwitch family cards.

Environmental & EMI Compliance

The JumboSwitch product family meets all pertinent industry-specific standards for environmental, performance and security requirements including IEC 61850-3, IEEE 1613, NEMA TS-2 and NERC CIP. Furthermore, future JumboSwitch family products will continue to be compliant with both existing and emerging industry standards and requirements, including developing Ethernet standards. Please refer to the charts below for specific standards compliance information.

	Tests	Industrial Standards	TC Communications - JumboSwitch Type Test and Levels	
			Power Supply Unit (PSU)	RJ-45 & Signal
Temperature/Humidity	Low Temperature Use	IEC 61850-3, IEEE 1613, NEMA TS-2	IEC 60068-2-1; Ae; -40°C; 16 hour	
	Low Temperature Storage	IEC 61850-3, IEEE 1613, NEMA TS-2		
	High Temperature Use	IEC 61850-3, IEEE 1613, NEMA TS-2	IEC 60068-2-2; Be; +80°C; 16 hour	
	High Temperature Storage	IEC 61850-3, IEEE 1613, NEMA TS-2	IEC 60068-2-2; Bd; +85°C; 16 hour	
	Damp Heat	IEC 61850-3, IEEE 1613, NEMA TS-2	IEC 60068-2-30; Db; +55°C; 95%; 96 hours	
Mechanical	Vibration	IEC 61850-3, IEEE 1613, NEMA TS-2	IEC 60068-2-6; Fc; 3 - 150 Hz; 7.5 mm; 2 g; 10 sweeps per axis	
	Shock	IEC 61850-3, IEEE 1613, NEMA TS-2	IEC 60068-2-27; Ea; 30g; 11ms	
ElectroMagnetic Compatibility	Electrostatic Discharge Immunity	IEEE 1613	IEC 61000-4-2; 8kV contact; 15 kV air	
	Radiated RF Immunity	IEC 61850-3, IEEE 1613	IEC 61000-4-3; 80 MHz - 1000 MHz; 20 V/m; AM 80% 1 kHz	
	EFT/Burst Immunity	IEC 61850-3, IEEE 1613	IEC 61000-4-4; 4 kV CM	IEC 61000-4-4; 4 kV CM
	Surge Immunity	IEC 61850-3	IEC 61000-4-5; 4 kV LG; 2 kV LL	IEC 61000-4-5; 4 kV LG; 2 kV LL
	Conducted RF immunity	IEC 61850-3	IEC 61000-4-6; 150 kHz - 80 MHz; 10 V; AM 80% 1 kHz	IEC 61000-4-6; 150 kHz - 80 MHz; 10 V; AM 80% 1 kHz
	Magnetic Field Immunity	IEC 61850-3	IEC 61000-4-8; 50 Hz; 100 A/m cont.; 1000 A/m 1 s	
	Damped Oscillatory Magnetic Field Immunity	IEC 61850-3	IEC 61000-4-10; 100 kHz; 30 A/m	
	Damped Oscillatory Magnetic Field Immunity	IEC 61850-3	IEC 61000-4-10; 1 MHz; 30 A/m	
Power Supply Unit (PSU) Variations	AC Voltage Dips	IEC 61850-3	IEC 61000-4-11; 30% & 100%, 0.5s	NA
	DC Voltage Dips	IEC 61850-3	IEC 61000-4-29; 40% & 70%, 0.1s	NA
	Damped Oscillatory Wave	IEC 61850-3	IEC 61000-4-12; 2.5 kV CM, 1.0 kV DM @1MHz	IEC 61000-4-12; 2.5 kV CM, 1.0 kV DM @ 1MHz
	Conducted PF CM Voltage	IEC 61850-3	IEC 61000-4-16; 50 Hz; 30 V cont.; 300 V 1s	IEC 61000-4-16; 50 Hz; 30 V cont.; 300 V 1s
	Conducted Emission	IEC 61850-3	CE/FCC/CISPR22 class A	CE/FCC/CISPR22 class A
	Conducted emission	IEC 61850-3	CE/FCC/CISPR22 class A	CE/FCC/CISPR22 class A
	Radiated emission	IEC 61850-3	CE/FCC/CISPR22 class A	
Dielectric	Dielectric 50 Hz Test	IEEE 1613	IEC 60255-5; 2 kV	IEC 60255-5; 0.5 kV
	Impulse Voltage Test	IEEE 1613	IEC60255-5; 5 kV	IEC 60255-5; 5 kV



Front View



Rear View

JumboSwitch 1S



Front View



Rear View

JumboSwitch 2S

JumboSwitch 1S & 2S Chassis, Front and Rear View.

JumboSwitch 1S

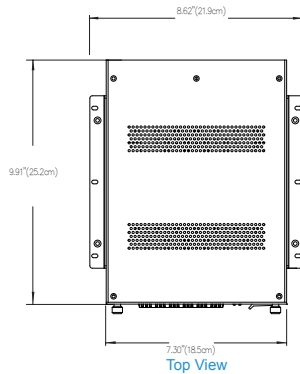
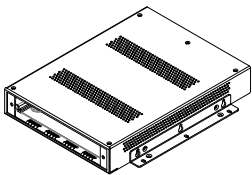

Top View

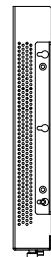

Side View

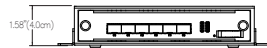

Front View

JumboSwitch 2S

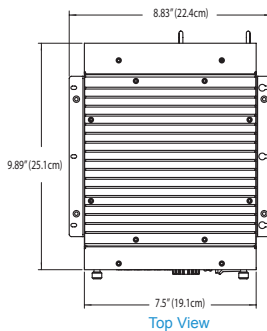
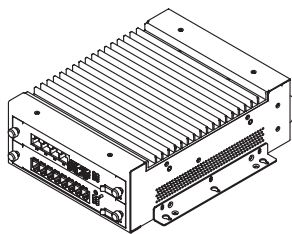

Top View

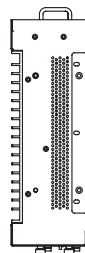

Side View

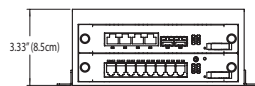

Front View

Note: Information contained in this data sheet is subject to change without prior notice.



ISO 9001
QMI-SAI Global
#1045959

TC Communications, Inc.
17881 Cartwright Road
Irvine, CA 92614 U.S.A.
Factory Tel: (949) 852-1972
Fax: (949) 852-1948

Sales Office
U.S.A. Domestic International
(800) 569-4736 (949) 852-1973

Web Site: www.tccomm.com
E-mail: sales@tccomm.com 1/09



www.JumboSwitch.com



DTS-38401525-01-02
Rev. 141217